

## CARACTERISTICAS

Movimento	Velocidade	Pot. dos motores
↑↓ Elevação	0 a 45 m/min.	7,5 kW
↻ Orientação	1 r.p.m.	2,2 kW
↔ Distribuição	0 a 45 m/min.	1,5 kW
🔧 Mont. Hidráulica	-	2,2 kW
⚡ Potência total		13,2 kVA
Tensão		400 v ±5% (50 Hz)

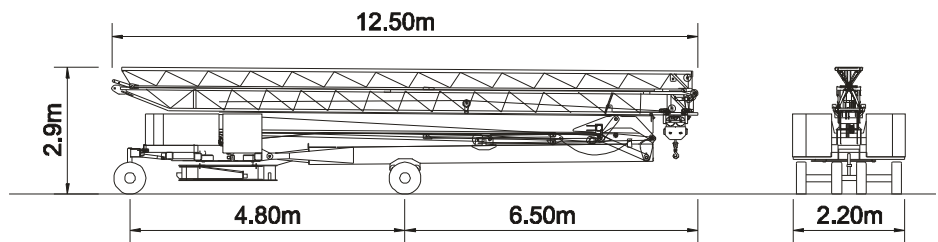

## DIAGRAMA DE CARGAS

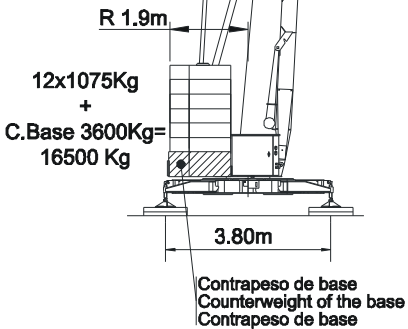
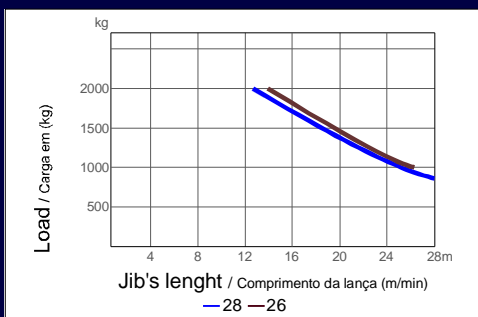

## DIAGRAMA DE VELOCIDADE

